

NO. E1FC-3618

ISSUED: OCT.2011

REVISED: OCT.2015



HOSHIZAKI SELF-CONTAINED CUBER

**MODEL IM-45CNE
IM-45CNE-25**

(E1FC, E1FC-D001,D002,D020)

PARTS LIST

[HE, GRAM]

A-1	NOV.	2011
B-0	JAN.	2012
B-1	OCT.	2012
C-0	JAN.	2013
D-0	JAN.	2014
D-1	APR.	2014
E-0	JAN.	2015
E-1	APR.	2015

AUXILIARY CODE

U - 1

The auxiliary code is the first two characters in the serial number. The first character indicates the production year. Years progress or regress in alphabetical order. The series of letters and skipped letters depend on UL listing, production, and model. See the auxiliary code(s) and corresponding year(s) on the front cover.

The second character indicates significant part changes within the same year. Base is "1" and this number advances for each change. If there is no significant part change at the turn of the year, this number starts from "0."

MARKS LOCATED UNDER THE AUXILIARY CODE

- = Part deleted.
- x = Part deleted and replaced by "o" part.
- o = New part in place of "x" part.

FASTENER PART NUMBER

SCREWS

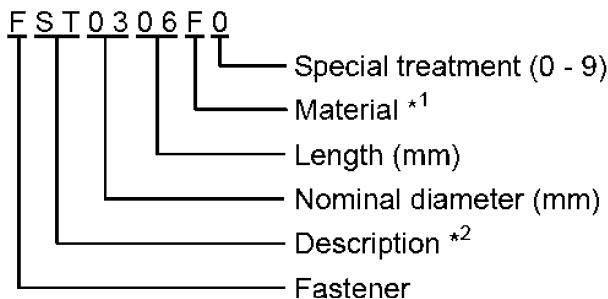

^{*1} Material

- F: Steel
- S: Austenitic stainless steel
- M: Martensitic stainless steel
- B: Copper alloy
- P: Polycarbonate
- N: Polyamide
- V: PVC
- A: ABS
- X: Polyacetal
- L: Aluminum

NUTS & WASHERS

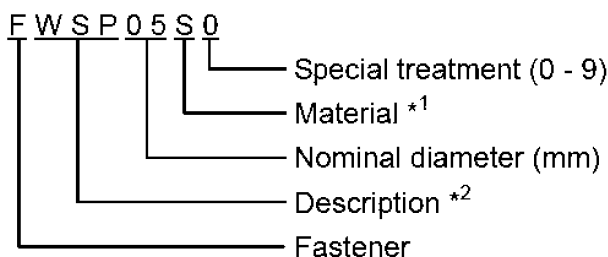

^{*2} Description

- First letter
- S: Machine screw
- T: Tapping screw
- M: Wood screw
- B: Bolt
- W: Washer
- N: Nut

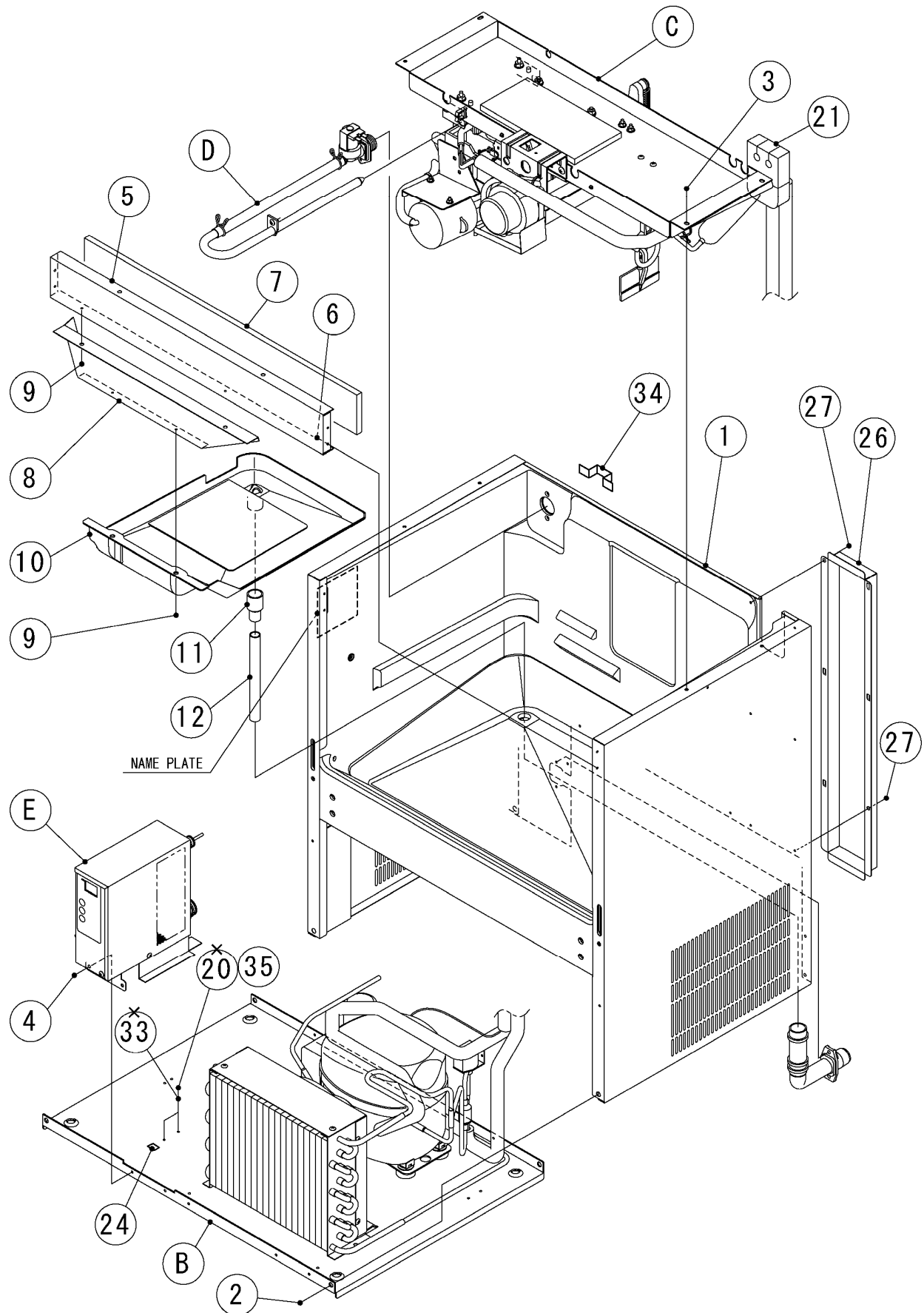

HE,GRAM

MODEL: IM-45CNE,IM-45CNE-25				TITLE: A.ICE CUBER ASSY			
INDEX NO.	DESCRIPTION	MATERIAL OR MODEL NUMBER	PART NUMBER	REQ'D NUMBER			
				A-1 B-0	B-1,C-0 D-0	D-1 E-0	E-1
B	REFRIGERATION ASSY		1H4827A01	1	1	1	1
C	ICE MAKING MECHANISM ASSY		1H4828A01	1	1	1	-
			1H4828A02	-	-	-	1
D	WATER CIRCUIT ASSY		3Y5610A01	1	1	1	1
E	CONTROL BOX ASSY		2X0439A01	1	-	-	-
			2X1218A01	-	1	1	1
F	DOOR ASSY		3Y5644A01	1	1	1	1
G	FRONT PANEL		3Y5645G01	1	1	1	1
1	UNIT FRAME		1H4826G01	1	1	-	-
			1H4826G02	-	-	1	1
2	TRUSS HEAD TAPPING SCREW T2	6*16	1H1765Z02	4	4	4	4
3	TRUSS HEAD MACHINE SCREW		FST0410S0	4	4	4	4
4	FLANGE BOLT (S-TITE)		FTR0408M0	2	2	2	2
5	FRONT FRAME		3X6086-02	1	1	1	1
6	RIVET	SSD42SSBS(t1.6~3.2)	7170-0002	4	4	4	4
7	INSULATION - FRONT FRAME		4Y1924-01	1	1	1	1
8	FRONT FRAME(LO)		2H4624-01	1	1	1	1
9	TRUSS HEAD TAPPING SCREW (S-TITE)		FTS0408M0	5	4	4	4
10	DRAIN PAN		2H1440-01	1	1	1	1
11	DRAIN TUBE		4H2585-01	1	1	1	1
12	DRAIN PIPE		4Y7493P04	1	1	1	1
13	HINGE (RIGHT)		4H2583-01	1	1	1	1
14	HINGE (LEFT)		4H2584-01	1	1	1	1
15	HEX HEAD BOLT (SPRING WASHER AND FLAT WASHER)		FBK0616S0	4	4	4	4
16	SLOPE		2H1349-02	1	1	1	1
17	SPRING		4X5639-01	1	1	1	1
18	TOP PANEL		2X0652M01	1	1	1	1
19	INSULATION - TOP		3Y5961P01	1	1	1	-
			3Y5961P02	-	-	-	1
20	TRUSS HEAD MACHINE SCREW		FST0408S0	4	2	2	2
21	INSULATION - BIN		4Y7416P01	1	1	1	1
22	TAPER COLLAR		4H0171-01	2	2	2	2
23	RIVET	SSD42BS	7170-0001	2	2	2	2

HE,GRAM

MODEL: IM-45CNE,IM-45CNE-25		TITLE: A.ICE CUBER ASSY					
INDEX NO.	DESCRIPTION	MATERIAL OR MODEL NUMBER	PART NUMBER	REQ'D NUMBER			
				A-1 B-0	B-1,C-0 D-0	D-1 E-0	E-1
24	LABEL - GROUND (B)		450452-02	1	1	1	1
25	SPRING WASHER		FWSP04S0	1	-	-	-
26	COVER - PIPE		3Y5868M01	1	1	-	-
			3Y8281M01	-	-	1	1
27	TRUSS HEAD TAPPING SCREW T2		FT20408F0	6	6	2	2
28	REAR COVER		3Y5855M01	1	1	1	1
29	TRUSS HEAD TAPPING SCREW T2		FT20408M0	6	6	6	6
30	CONNECTOR		P00245-02	1	1	1	1
31	POWER SUPPLY CORD	EU-PLUG(10A)	P03359-01	1	1	1	1
		UK-PLUG(10A)	P03360-01	1	1	1	1
		AS-PLUG(10A)	P03361-01	1	1	1	1
		KC-PLUG(10A)	P03365-01	1	1	1	1
32	COVER - CONNECTOR	ACCESSORIES NO.5	2X0271P01	1	1	1	1
33	TOOTH WASHER		FWTB04S0	2	-	-	-
34	CAUTION - LABEL		452552-01	1	1	1	1
35	PAN HEAD SCREW SW		FSK0408S0	-	3	3	3

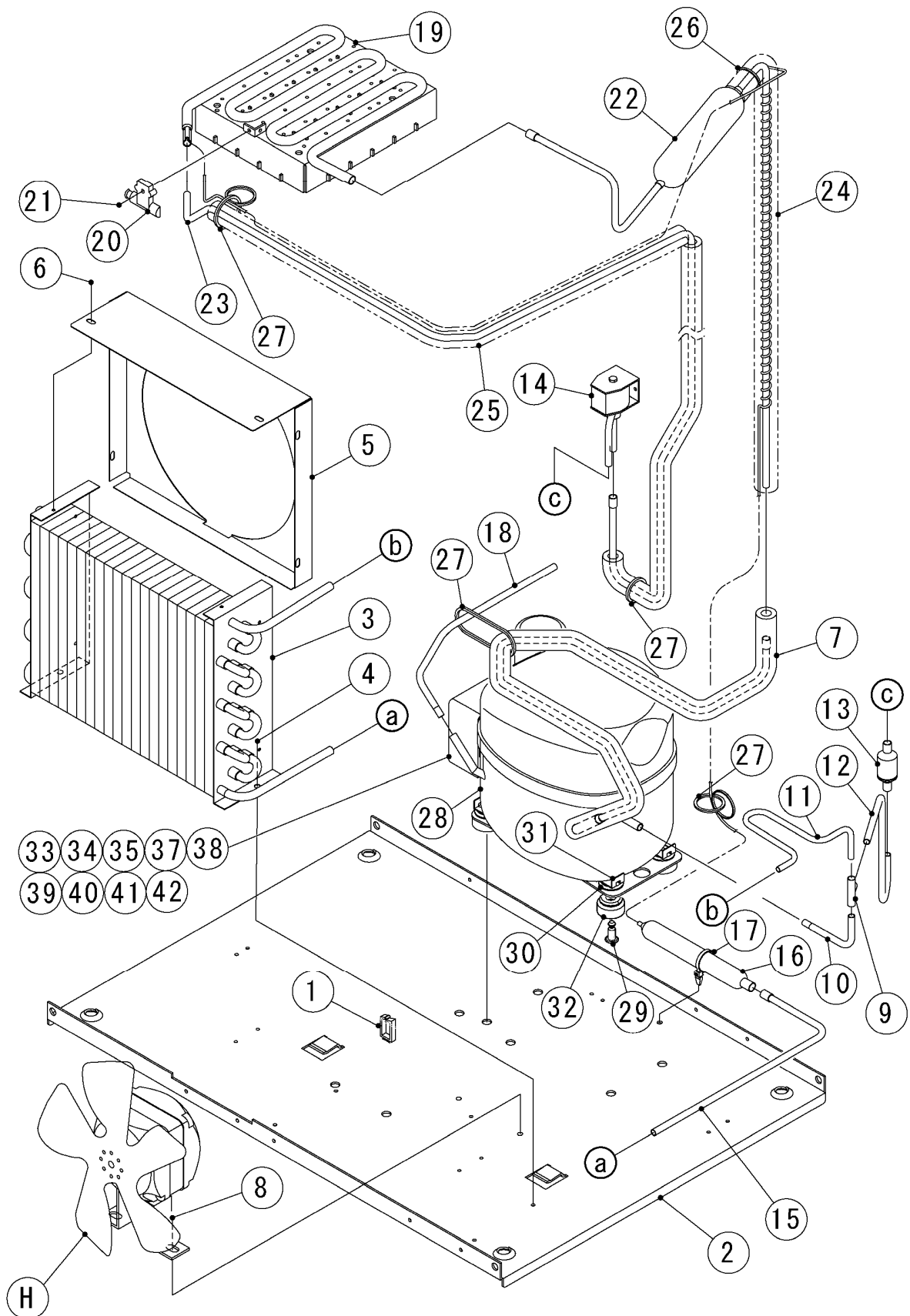

HE,GRAM

MODEL: IM-45CNE,IM-45CNE-25				TITLE: B.REFRIGERATION ASSY			
INDEX NO.	DESCRIPTION	MATERIAL OR MODEL NUMBER	PART NUMBER	REQ'D NUMBER			
				A-1 B-0	B-1,C-0 D-0	D-1 E-0	E-1
H	FAN MOTOR ASSY		3Y5605A01	1	1	1	1
1	WIRE SADDLE		428060-02	1	1	1	1
2	BASE		1H4829M01	1	1	1	1
3	CONDENCER		P03372-01	1	1	1	1
4	FLANGE BOLT (S-TITE)		FTR0408M0	2	2	2	2
5	SHROUD		3Y5606M01	1	1	1	1
6	TRUSS HEAD TAPPING SCREW T2		FT20408F0	6	6	6	6
7	PIPE(A) - LOW SIDE		3Y5607G01	1	1	1	1
8	HEX HEAD BOLT (SPRING WASHER AND FLAT WASHER)		FBK0612F0	2	2	2	2
9	TEE		417394-01	1	1	1	1
10	PIPE(A) - HIGH SIDE		4Y7160M01	1	1	1	1
11	PIPE(B) - HIGH SIDE		4Y7161M01	1	1	1	1
12	PIPE(A) - HOT		4Y7162M01	1	1	1	1
13	STRAINER		P00008-01	1	1	1	1
14	HOT GAS VALVE		P02539-01	1	1	1	1
15	PIPE(C) - HIGH SIDE		4Y7163M01	1	1	1	1
16	DRIER		P03584-01	1	1	1	1
17	TIE		457167-01	2	2	2	2
18	PROSESS PIPE		4Y7164M01	1	1	1	1
19	EVAPORATOR	(IM-45CNE)	3H5611G02	1	1	1	1
		(IM-45CNE-25)	3H3941G01	1	1	1	1
20	HOLDER - THERMISTOR		3H9642-01	1	1	1	1
21	TRUSS HEAD TAPPING SCREW (S-TITE)		FTS0408M0	1	1	1	1
22	HEAT EXCHANGER		4X5640G01	1	1	1	1
23	PIPE(B) - HOT		3Y5859G01	1	1	1	1
24	Insulation Tube - FSA		H81323450	1	1	1	1
25	Insulation Tube (Food Sanitation Law)		H81020650	1	1	1	1
26	NYLON TIE	CV-100	7920-0002	1	1	1	1
27	NYLON TIE	CV-100	7920-0002	4	4	4	4
28	COMPRESSOR	(50Hz)	P02286-01	1	1	1	1
		(60Hz)	P02617-01	1	1	1	1
29	PIN		P02605-01	4	4	4	4
30	WASHER		P02606-01	4	4	4	4
31	CLAMP		P02607-01	4	4	4	4

HE,GRAM

MODEL: IM-45CNE,IM-45CNE-25				TITLE: B.REFRIGERATION ASSY			
INDEX NO.	DESCRIPTION	MATERIAL OR MODEL NUMBER	PART NUMBER	REQ'D NUMBER			
				A-1 B-0	B-1,C-0 D-0	D-1 E-0	E-1
32	RUBBER GROMMET		P02608-01	4	4	4	4
33	HERMETIC TERMINAL COVER		P03143-01	1	1	1	1
34	SCREW		P00840-01	2	2	2	2
35	BRACKET FOR CAPACITOR		P02610-01	1	1	1	1
36	START CAPACITOR	(50Hz)	P02620-01	1	1	1	1
		(60Hz)	P02611-01	1	1	1	1
37	TERMINAL BOARD		P02612-01	1	1	1	1
38	STARTING RELAY	(50Hz)	P02613-01	1	1	1	1
		(60Hz)	P02619-01	1	1	1	1
39	MOTER PROTECTOR	(50Hz)	P02618-01	1	1	1	1
		(60Hz)	P02614-01	1	1	1	1
40	Overload Protector Bracket		P03144-01	1	1	1	1
41	SELF TAPPING SCREW M4-11		P02615-01	1	1	1	1
42	SELF TAPPING SCR W M4-21		P02616-01	1	1	1	1

IM-45CNE
IM-45CNE-25 C. ICE MAKING MECHANISM ASSY (A-1) and later

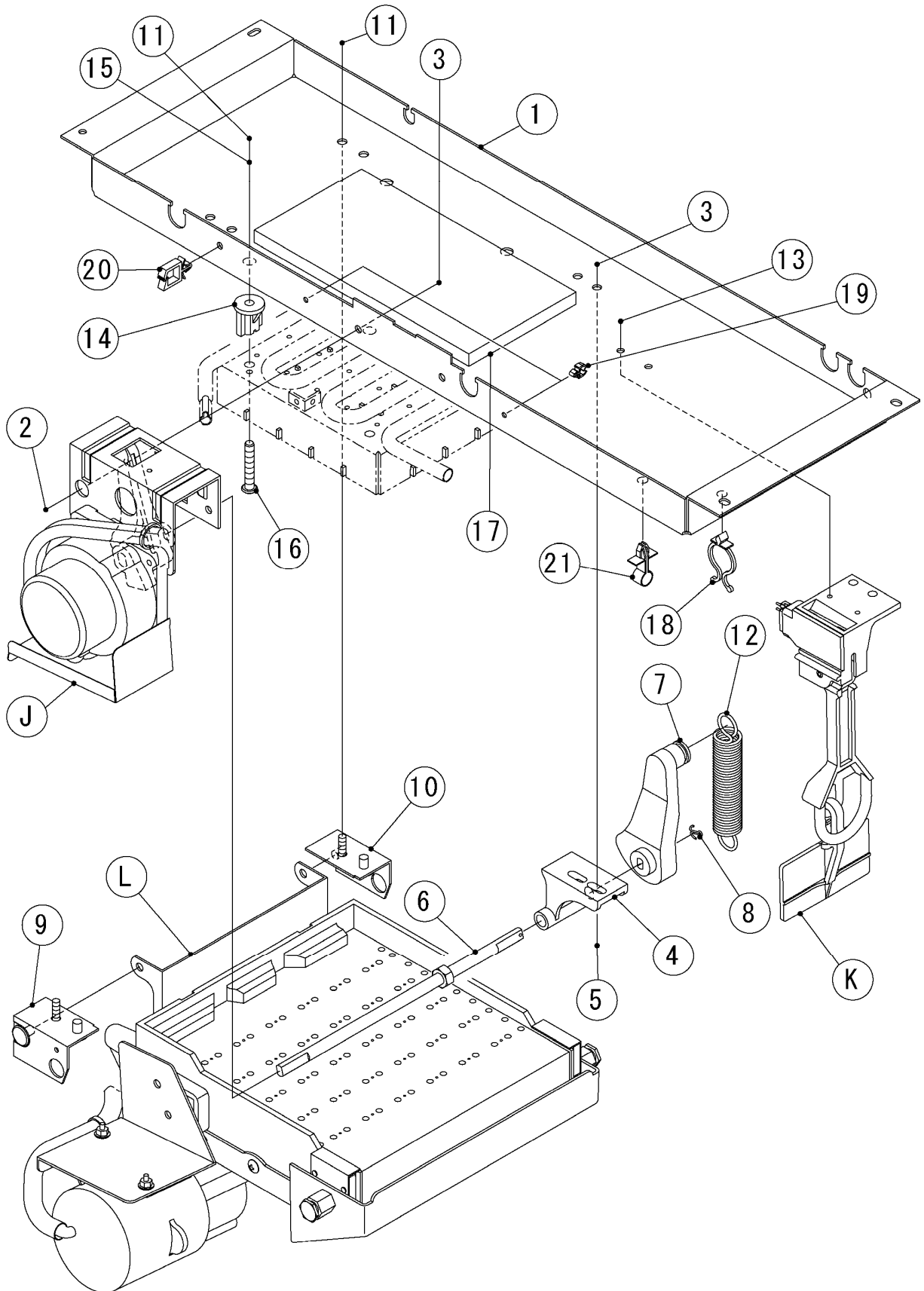

HE,GRAM

MODEL: IM-45CNE,IM-45CNE-25				TITLE: C.ICE MAKING MECHANISM ASSY			
INDEX NO.	DESCRIPTION	MATERIAL OR MODEL NUMBER	PART NUMBER	REQ'D NUMBER			
				A-1 B-0	B-1,C-0 D-0	D-1 E-0	E-1
J	ACTUATOR MOTOR ASSY		3Y5641A01	1	1	1	-
			3Y8837A01	-	-	-	1
K	BIN SWITCH ASSY		3H1537A08	1	1	1	1
L	WATER PAN ASSY		2X0437A01	1	1	1	1
1	BRACKET - ICE MAKING MECHANISM	(IM-45CNE)	2X0468M01	1	1	1	1
		(IM-45CNE-25)	2X0910M01	1	1	1	1
2	TRUSS HEAD MACHINE SCREW		FST0512S0	2	2	2	2
3	FLANGE NUT		FNHF05S0	4	4	4	4
4	CAM SHAFT BEARING		307256-02	1	1	1	1
5	TRUSS HEAD MACHINE SCREW		FST0516S0	2	2	2	2
6	CAM SHAFT		4H2589G01	1	1	1	1
7	CAM (B)		3H1389-01	1	1	1	1
8	COTTER PIN		711S-0212	1	1	1	1
9	BEARING (FRONT) - WATER PAN		4H2591G02	1	1	1	1
10	BEARING (REAR) - WATER PAN		4H2592G02	1	1	1	1
11	FLANGE NUT		FNHF06S0	6	6	6	6
12	SPRING		4H2640-01	1	1	1	1
13	TRUSS HEAD TAPPING SCREW T2		FT20410M0	2	2	2	2
14	SPACER	(IM-45CNE)	4H0471-01	4	4	4	4
		(IM-45CNE-25)	4X5342-01	4	4	4	4
15	WASHER		4H0777-01	4	4	4	4
16	SCREW EVAPORATOR		4Y4922M01	4	4	4	4
17	INSULATION (D)		4Y7347P01	1	1	1	1
18	CLAMP	No.2674	427902-02	1	1	1	1
19	CLAMP		426197-01	2	2	2	2
20	WIRE SADDLE		428060-03	1	1	1	1
21	CLAMP		428644-02	1	1	1	1

IM-45NE
IM-45NE-25
IM-45WNE
IM-45WNE-25
IM-45CNE
IM-45CNE-25

D. WATER CIRCUIT ASSY

(A-1) and later

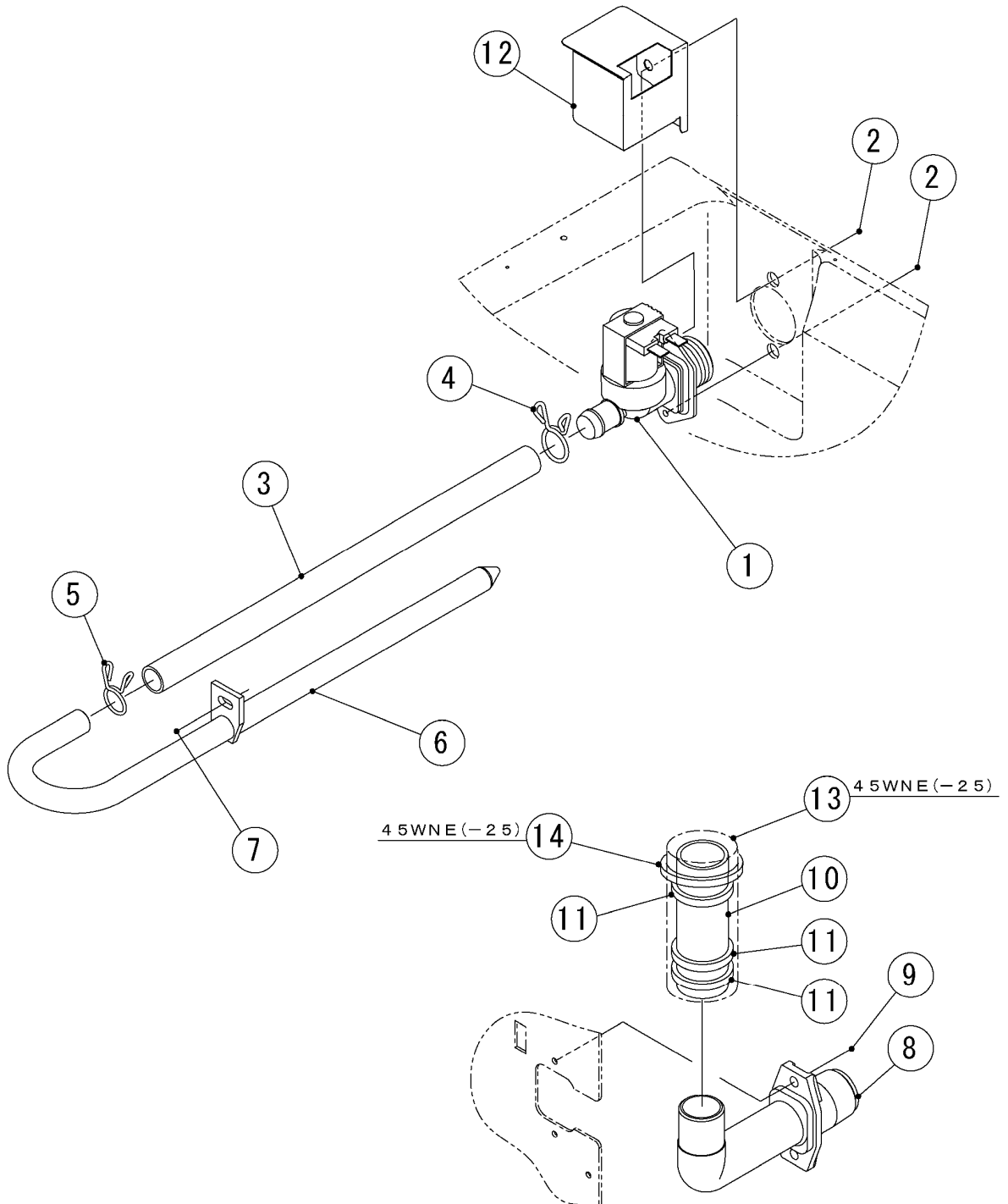

HE,GRAM

MODEL: IM-45CNE,IM-45CNE-25				TITLE: D.WATER CIRCUIT ASSY			
INDEX NO.	DESCRIPTION	MATERIAL OR MODEL NUMBER	PART NUMBER	REQ'D NUMBER			
				A-1 B-0	B-1,C-0 D-0	D-1 E-0	E-1
1	WATER VALVE		P02056-01	1	1	1	1
2	HEX SOCKET HEAD CAP SCREW		FBX0408S0	2	2	2	2
3	SILICONE HOSE		3H9599-03	1	1	1	1
4	HOSE CLAMP		435934-03	1	1	1	1
5	HOSE CLAMP		435934-02	1	1	1	1
6	WATER SUPPLY PIPE		3H9530G01	1	1	1	1
7	TRUSS HEAD MACHINE SCREW		FST0408S0	1	1	1	1
8	DRAIN PIPE		3H0394-01	1	1	1	1
9	TRUSS HEAD TAPPING SCREW T2		FT20408S0	2	2	2	2
10	VINYL HOSE		3Y5610Z01	1	1	1	1
11	TIE	CV-150	7920-0003	3	3	3	3
12	COVER-WATER VALVE		3Y6277M01	1	1	1	1

IM-45NE
IM-45NE-25
IM-45WNE
IM-45WNE-25
IM-45CNE
IM-45CNE-25

E. CONTROL BOX ASSY

(A-1) and later

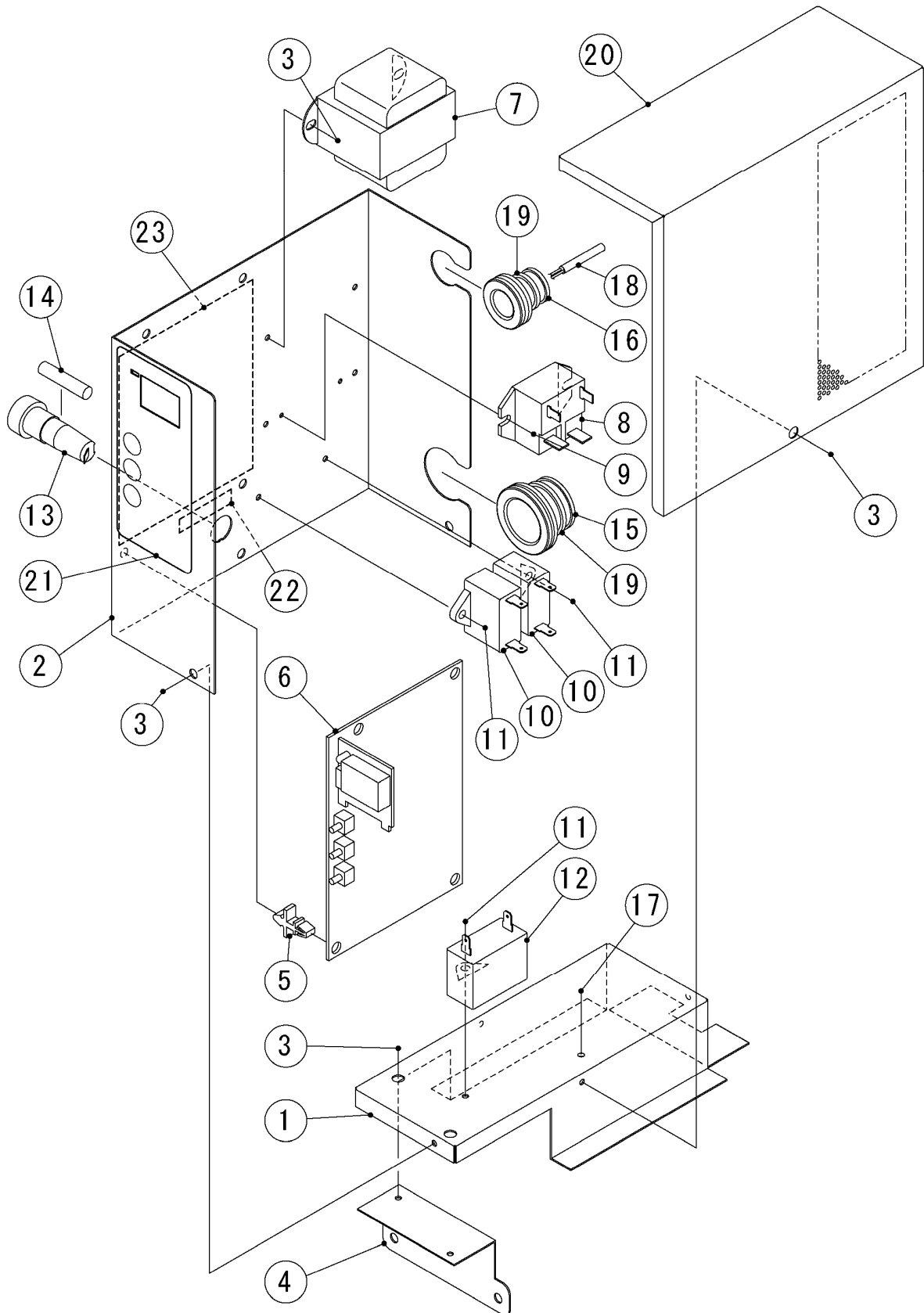

HE,GRAM

MODEL: IM-45CNE,IM-45CNE-25				TITLE: E.CONTROL BOX ASSY			
INDEX NO.	DESCRIPTION	MATERIAL OR MODEL NUMBER	PART NUMBER	REQ'D NUMBER			
				A-1 B-0	B-1,C-0 D-0	D-1 E-0	E-1
1	CONTROL BOX (A)		3Y5611M01	1	1	1	1
2	CONTROL BOX(B)		2X0438M01	1	-	-	-
			2X1216M01	-	1	1	1
3	TRUSS HEAD TAPPING SCREW T2		FT20408F0	8	8	8	8
4	PLATE - BOX		4Y7215M01	1	1	1	1
5	BOARD SUPPORT		414929-02	4	4	4	4
6	CONTROLLER BOARD		P01873-01	1	1	1	1
7	TRANSFORMER		P02714-01	1	1	1	1
8	POWER RELAY		P02203-02	1	1	1	1
9	TRUSS HEAD TAPPING SCREW T2		FT20308F0	2	2	2	2
10	CAPACITOR		P01870-01	2	2	2	2
11	TRUSS HEAD TAPPING SCREW T2		FT20410F0	3	3	3	3
12	CONDENSER		P02158-01	1	1	1	1
13	FUSE HOLDER		P00014-01	1	-	-	-
			P02829-01	-	1	1	1
14	FUSE		P01876-01	1	-	-	-
			P01992-01	-	1	1	1
15	GROMMET		4H2568-01	1	1	1	1
16	GROMMET		4H2568-02	1	1	1	1
17	TRUSS HEAD MACHINE SCREW		FST0408S0	1	1	1	1
18	THERMISTOR - CUBE COTROL		P00350-01	1	1	1	1
19	TIE	CV-150	7920-0003	2	2	2	2
20	CONTROL BOX COVER		3Y5612M01	1	1	1	1
21	CONTROL LABEL		475642L01	1	1	1	1
22	LABEL - FUSE		466798-01	1	1	1	1
23	WIRING LABEL		3Y5648L01	1	1	1	1

IM-45CNE
IM-45CNE-25

F. DOOR ASSY

(A-1) and later

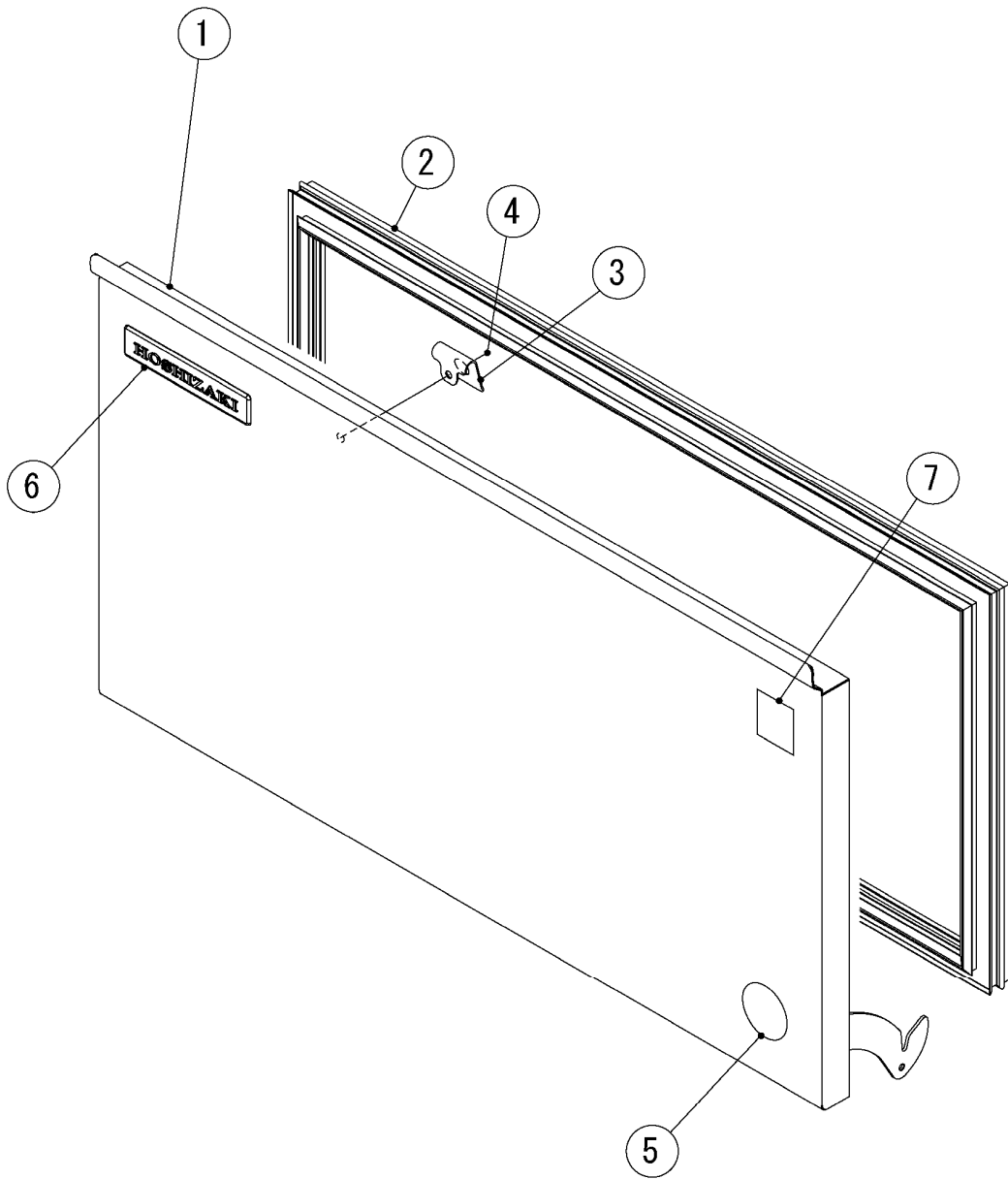

HE,GRAM

MODEL: IM-45CNE,IM-45CNE-25		TITLE: F.DOOR ASSY					
INDEX NO.	DESCRIPTION	MATERIAL OR MODEL NUMBER	PART NUMBER	REQ'D NUMBER			
				A-1 B-0	B-1,C-0 D-0	D-1 E-0	E-1
1	DOOR - INSULATION		2X0466G01	1	1	1	1
		(GRAM)	2X0466G03	-	1	1	1
2	DOOR GASKET		3Y6199P03	1	1	1	1
3	CATCH - SLOPE		4X7644-01	1	1	1	1
4	TRUSS HEAD TAPPING SCREW T2		FT20408M0	1	1	1	1
5	LABEL - PENGUIN	(Except GRAM)	471486L01	1	1	1	1
6	EMBLEM		340842-01	1	1	1	1
	EMBLEM-GRAM	(GRAM)	4Y6123L01	-	1	1	1
7	LABEL - HACCP		476519L01	1	1	1	1

IM-45CNE
IM-45CNE-25 G. FRONT PANEL LOWER ASSY (A-1) and later

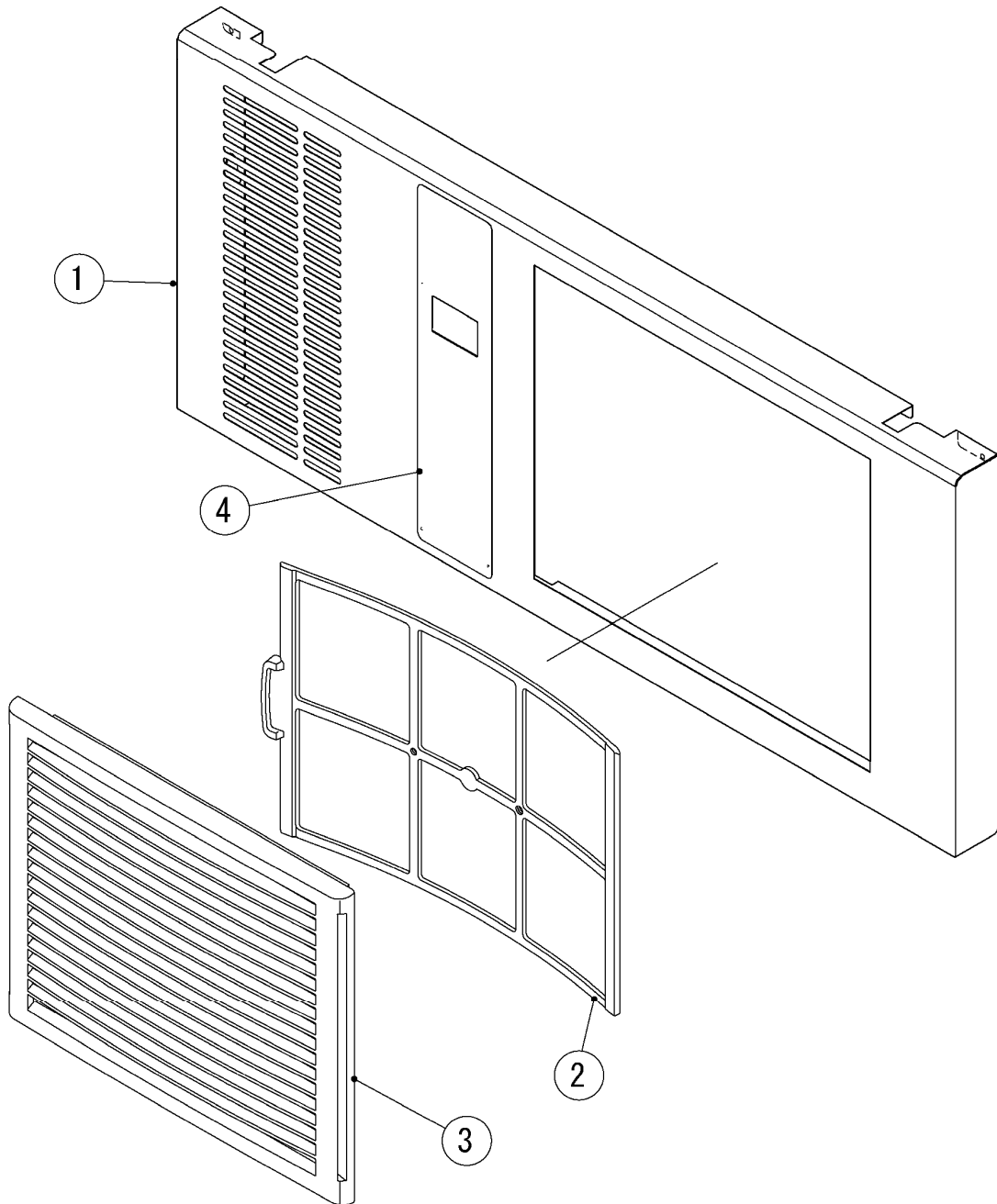

HE,GRAM

MODEL: IM-45CNE,IM-45CNE-25		TITLE: G.FRONT PANEL LOWER ASSY					
INDEX NO.	DESCRIPTION	MATERIAL OR MODEL NUMBER	PART NUMBER	REQ'D NUMBER			
				A-1 B-0	B-1,C-0 D-0	D-1 E-0	E-1
1	FRONT PANEL		2X0467M01	1	1	1	1
2	AIR FILTER		2X0416G01	1	1	1	1
3	LOUVER		1H4811P01	1	1	1	1
4	OPERATION LABEL		375116L03	1	1	1	1

IM-45NE
IM-45NE-25
IM-45CNE
IM-45CNE-25

H. FAN MOTOR ASSY

(A-1) and later

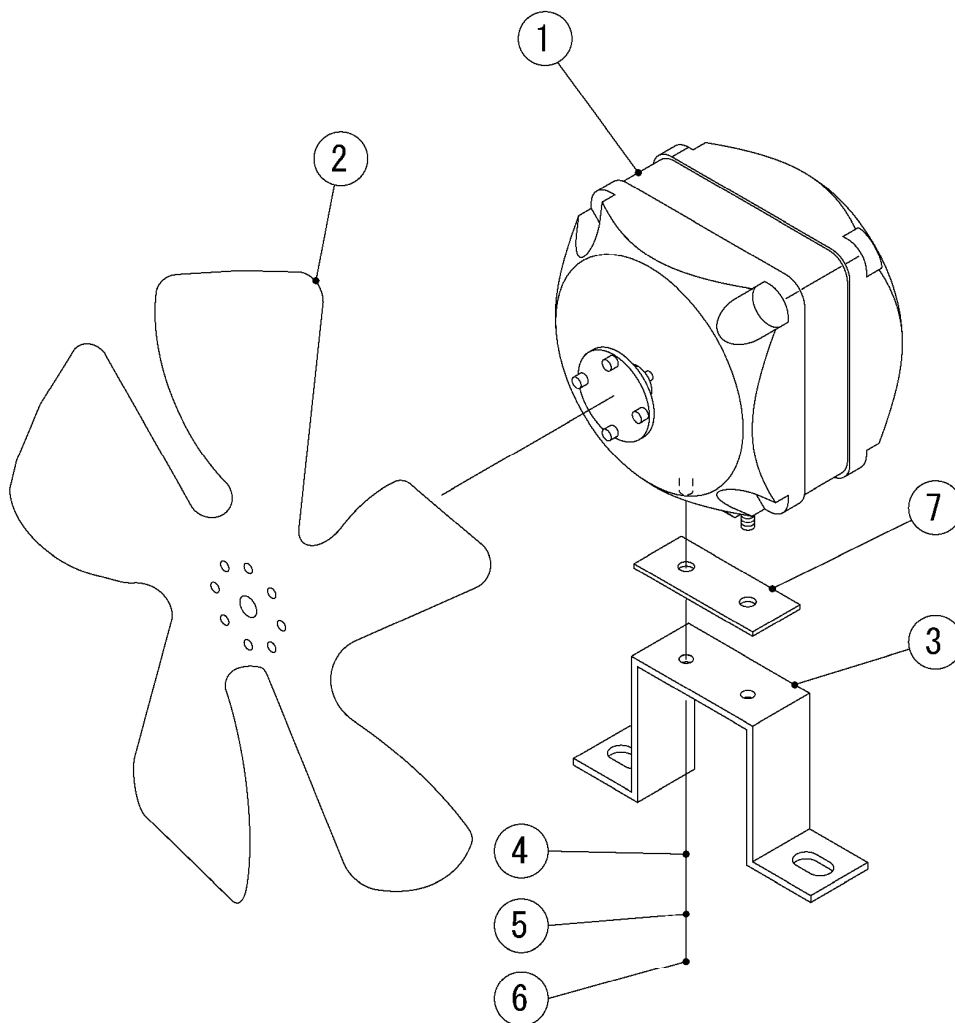

HE,GRAM

MODEL: IM-45CNE,IM-45CNE-25		TITLE: H.FAN MOTOR ASSY					
INDEX NO.	DESCRIPTION	MATERIAL OR MODEL NUMBER	PART NUMBER	REQ'D NUMBER			
				A-1 B-0	B-1,C-0 D-0	D-1 E-0	E-1
1	FAN MOTOR		P00022-01	1	1	1	1
2	FAN		451770-01	1	1	1	1
3	BRACKET - FM		3Y5970M01	1	1	1	1
4	FLAT WASHER		FWPL04S0	2	2	2	2
5	SPRING WASHER		FWSP04S0	2	2	2	2
6	NUT		FNH104S0	2	2	2	2
7	SPACER		4X3927-01	1	1	1	1

IM-45NE
IM-45NE-25
IM-45WNE
IM-45WNE-25
IM-45CNE
IM-45CNE-25

J. ACTUATOR MOTOR ASSY

(A-1) and later

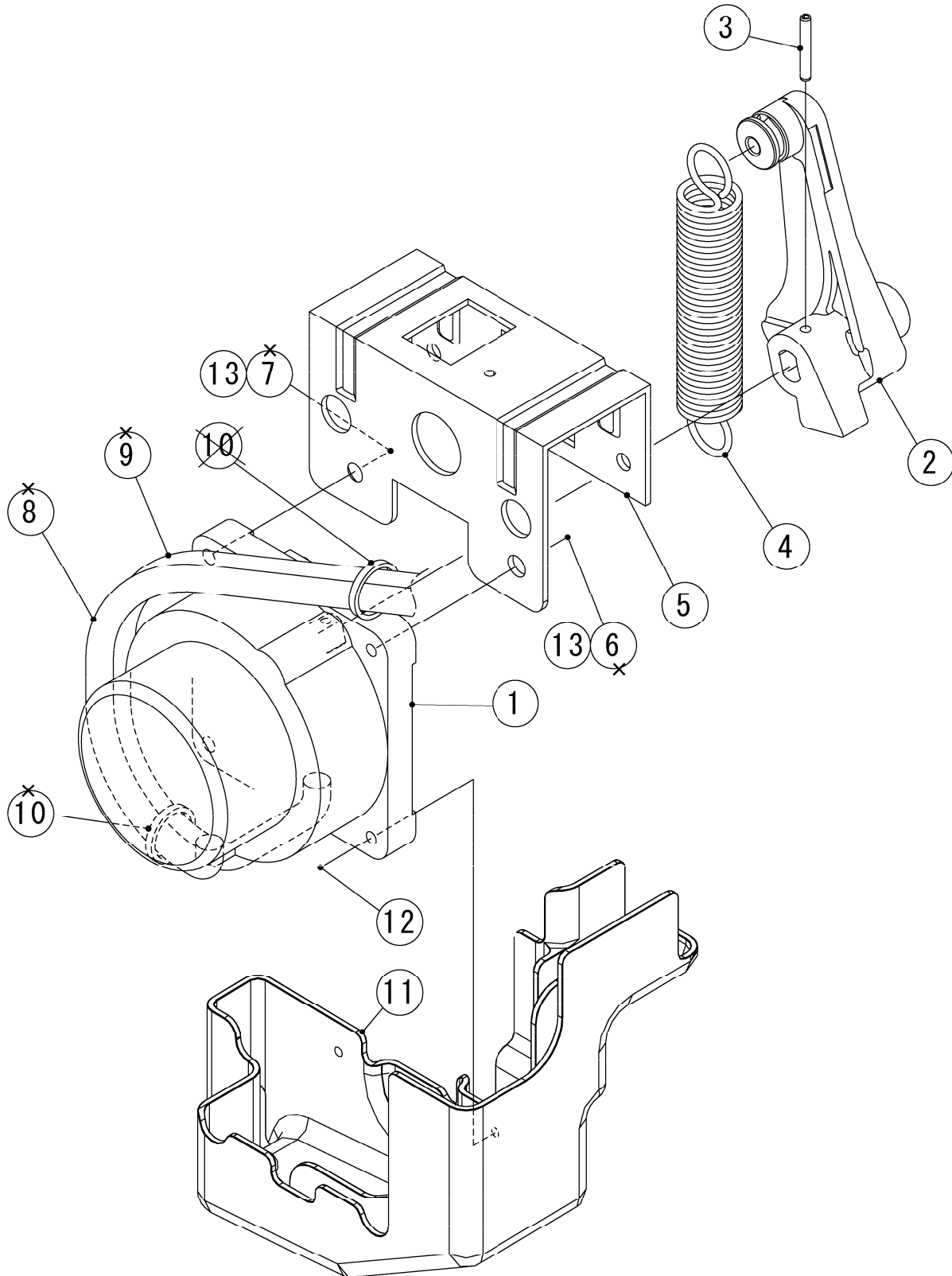

HE,GRAM

MODEL: IM-45CNE,IM-45CNE-25		TITLE: J.ACTUATOR MOTOR ASSY					
INDEX NO.	DESCRIPTION	MATERIAL OR MODEL NUMBER	PART NUMBER	REQ'D NUMBER			
				A-1 B-0	B-1,C-0 D-0	D-1 E-0	E-1
1	ACTUATOR MOTOR		P01869-01	1	1	1	-
			4Y8998G01	-	-	-	1
2	CAM (A)		3Y2277P01	1	1	1	1
3	SPRING PIN		712S-0322	1	1	1	1
4	SPRING		4H2640-01	1	1	1	1
5	BRACKET - ACTUATOR MOTOR		3H1388-04	1	1	1	-
			3Y8832M01	-	-	-	1
6	TRUSS HEAD MACHINE SCREW		FST0612S0	1	1	1	-
7	FLAT HEAD MACHINE SCREW		FSF0612S0	1	1	1	-
8	TUBE - SILICONE		4Y6751Z08	1	1	1	-
9	TUBE - SILICONE		4X8017-01	1	-	-	-
10	TIE	CV-150	7920-0003	1	1	1	-
11	COVER - ACTUATOR MOTOR		1H4881P01	1	1	1	1
12	T2 TRUSS HEAD SCREW		FT20418M0	2	2	2	2
13	HEX HEAD BOLT (SPRING WASHER AND FLAT WASHER)		FBK0620S0	-	-	-	2

IM-45CNE
IM-45CNE-25

K. BIN SWITCH ASSY

(A-1) and later

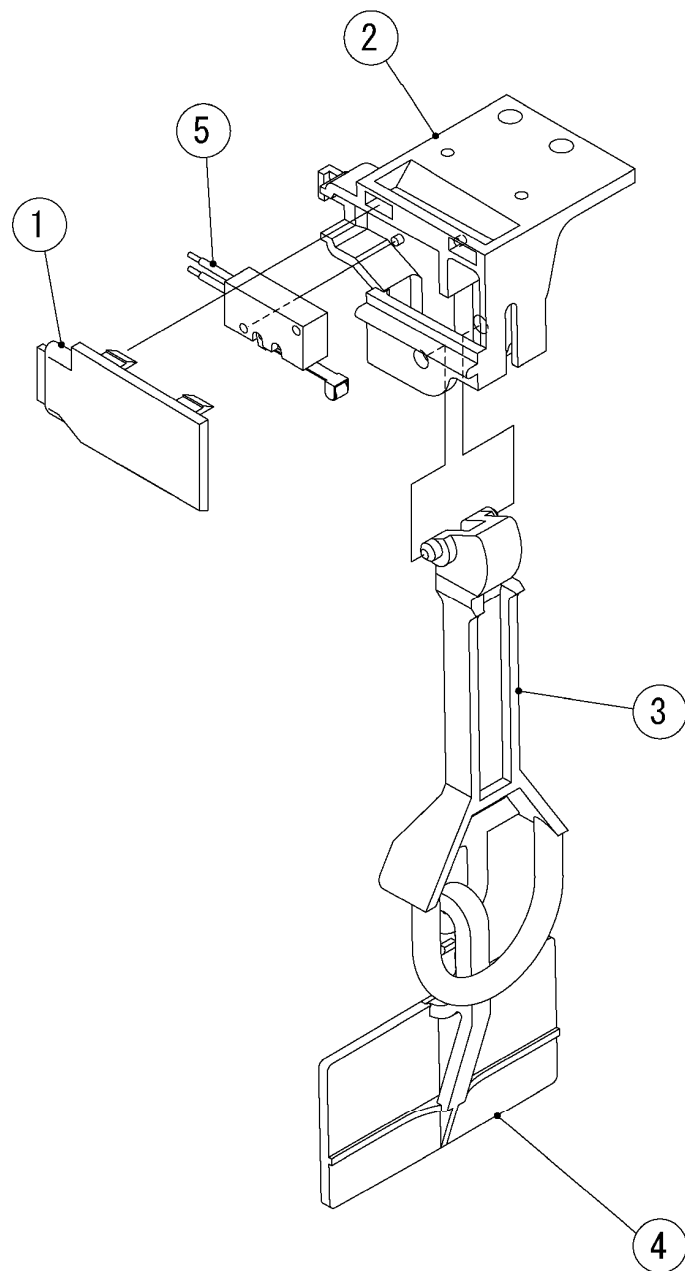

HE,GRAM

MODEL: IM-45CNE,IM-45CNE-25		TITLE: K.BIN SWITCH ASSY					
INDEX NO.	DESCRIPTION	MATERIAL OR MODEL NUMBER	PART NUMBER	REQ'D NUMBER			
				A-1 B-0	B-1,C-0 D-0	D-1 E-0	E-1
1	SWITCH BOX COVER		4H8785-01	1	1	1	1
2	SWICH BOX		2H2043-01	1	1	1	1
3	SWITCH ACTUATOR		3H1369-01	1	1	1	1
4	DETECTOR		3H9308-01	1	1	1	1
5	MICRO SWITCH		456432-02	1	1	1	1

IM-45NE
IM-45NE-25
IM-45WNE
IM-45WNE-25
IM-45CNE
IM-45CNE-25

L. WATER PAN ASSY

(A-1) and later

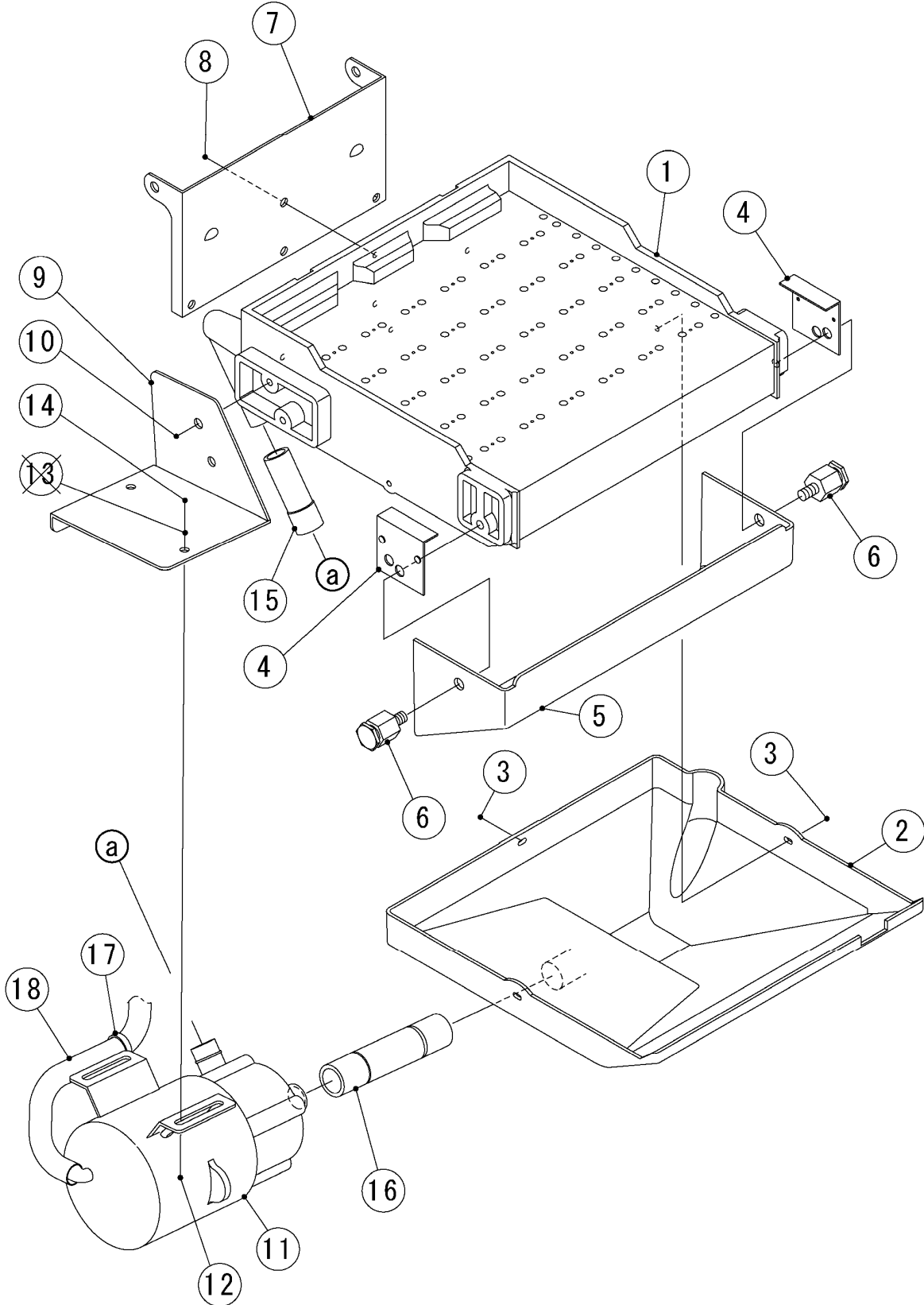

HE,GRAM

		MODEL: IM-45CNE,IM-45CNE-25		TITLE: L.WATER PAN ASSY			
INDEX NO.	DESCRIPTION	MATERIAL OR MODEL NUMBER	PART NUMBER	REQ'D NUMBER			
				A-1 B-0	B-1,C-0 D-0	D-1 E-0	E-1
1	WATER PLATE	(IM-45CNE)	2H0402G02	1	1	1	1
		(IM-45CNE-25)	2H0402G03	1	1	1	1
2	WATER TANK(AD)		4X4159-02	1	1	1	1
3	TRUSS HEAD TAPPING SCREW T2		FT20408M0	3	3	3	3
4	PLATE - LUBRICATION		4H0448-01	2	2	2	2
5	DRAIN GUIDE		3H5521-01	1	1	1	1
6	SCREW SPRING HOOK		4H2582G01	2	2	2	2
7	BRACKET - WATER PAN		4H2643-02	1	1	1	1
8	TRUSS HEAD TAPPING SCREW T2		FT20412M0	4	4	4	4
9	BRACKET - PUMP MOTOR		4Y7294M01	1	1	1	1
10	TRUSS HEAD TAPPING SCREW T2		FT20512M0	2	2	2	2
11	PUMP MOTOR		P02132-01	1	1	1	1
12	HEX HEAD BOLT (SPRING WASHER AND FLAT WASHER)		FBK0412S0	2	2	2	2
13	FLAT WASHER		FWPL04S0	-			
14	FLANGE NUT		FNHF04S0	2	2	2	2
15	DISCHARGE TUBING		4H1982-01	1	1	1	1
16	SUCTION TUBING		4H1922-02	1	1	1	1
17	NYLON TIE	CV-70	7920-0001	1	1	1	1
18	TUBE - SILICONE		4Y6751Z03	1	1	1	1

IM-45NE
IM-45NE-25
IM-45WNE
IM-45WNE-25
IM-45CNE
IM-45CNE-25

M. ACCESSORIES

(A-1) and later

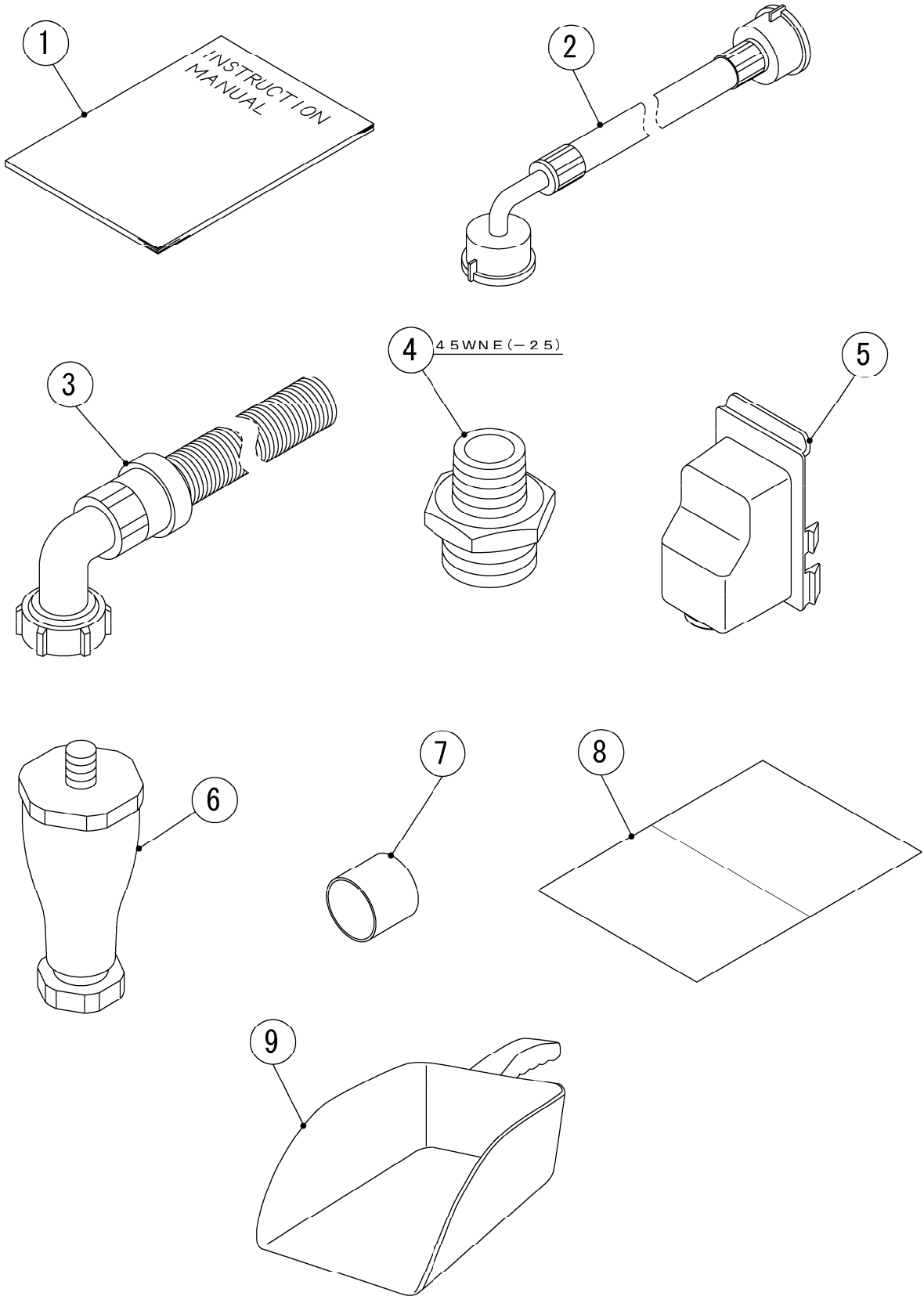

HE,GRAM

MODEL: IM-45CNE,IM-45CNE-25				TITLE: M.ACCESSORIES			
INDEX NO.	DESCRIPTION	MATERIAL OR MODEL NUMBER	PART NUMBER	REQ'D NUMBER			
				A-1 B-0	B-1,C-0 D-0	D-1 E-0	E-1
1	INSTRUCTION MANUAL		L1E1EC201	1	1	1	1
2	INLET HOSE	TC138-AF-HY	P03534-01	1	1	1	1
3	OUTLET HOSE		452365-01	1	1	1	1
4	-		-	-	-	-	-
5	COVER - CONNECTOR		2X0271P01	1	1	1	1
6	LEG		462576-02	4	4	4	4
7	CAP		417323-01	1	1	1	1
8	INSTRUCTION SHEET		121594L01	1	1	1	1
9	SCOOP		P00314-01	1	1	1	1